

PARAMETER GENERATION & CONTROL

PRECISE HUMIDITY CONTROL SYSTEMS

30 Cubic Foot Chamber



AN UNSURPASSED RH CONTROL OF $\pm 0.5\%$

The PGC 30 cu. ft. chamber features our unique humidity control system that enables the user to attain unsurpassed levels of RH/temperature control and uniformity.

These test chambers are designed to accurately produce those temperature and humidity conditions required for applications such as stability studies, package testing, TAPPI, MIL-SPEC, and vapor transmission.

Applications are found in such diverse industries as pharmaceutical development and manufacturing, electronic components, food, semiconductor, paper and pulp, and wherever precise humidity and temperature replications are required.

Additionally, PGC's SmartPad microprocessor controller is a user-friendly system that provides optimum accuracy and control. The SmartPad is equipped with direct readings in both temperature and humidity. It also features 60-segment programming for automatic cycling and ramping and soaking excursions. High-low or deviation alarms as well as digital communications ports are standard features.

The interior chamber is constructed of a very durable, corrosion resistant 316 stainless steel. Low watt density heaters are used that also contribute to the unit's longer life.

Should your application require it, the chamber airflow can be factory configured from the standard horizontal flow to vertical. Other options include extended ranges, chart recorders, a window in the outer door, and a clear inner door with optional iris opening.

Lastly, all PGC equipment is exhaustively tested at your specified condition before being shipped to ensure trouble-free operation.

EXTREMELY PRECISE CONTROL
LOW ENERGY REQUIREMENTS
LOW MAINTENANCE

RH VARIABLES	PGC, INC.	COMPETITION
TOTAL	$\pm 2.5\%$	$\pm 6.0\%$
CONTROL CONSTANCY	$\pm 0.5\%$	$\pm 2.0\%$
CHAMBER UNIFORMITY	$\pm 1.0\%$	$\pm 2.0\%$
SENSOR ACCURACY	$\pm 1.0\%$	$\pm 2.0\%$

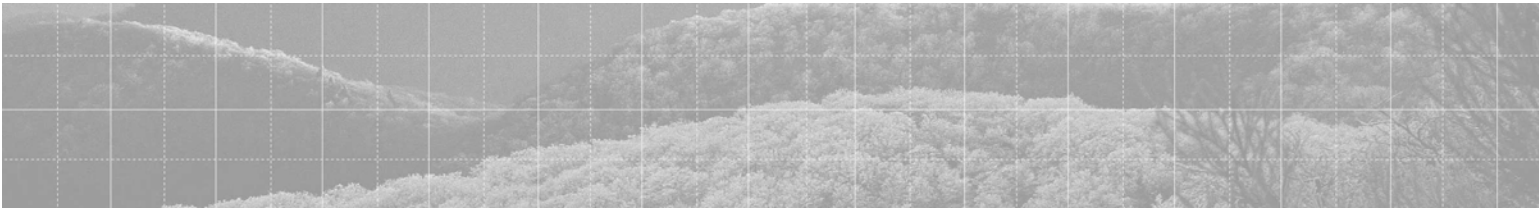

SPECIFICATIONS

SERIES 9130

Relative Humidity Range: 10 to 95% (limited by a 4°C dew point)

Relative Humidity Constancy: $\pm 0.5\%$

Relative Humidity Uniformity: $\pm 1.0\%$

Temperature Range: 5 to 85°C

Temperature Constancy: $\pm 0.2^\circ\text{C}$

Temperature Uniformity: $\pm 0.2^\circ\text{C}$

UTILITIES

220v, 20.5 FLA, 1 phase, 60 Hz

220v, 12 FLA, 1 phase, 50 Hz

Higher voltages are also available

Refrigerant: R-134A (non-ozone depleting gas)

EXTERNAL CHAMBER DIMENSIONS

53.5" w x 36" d x 79" h (nominal)

INTERNAL CHAMBER DIMENSIONS

34.5" w x 28.75" d x 52.5" h (nominal)

WEIGHT

750 lbs.

SHIPPING WEIGHT

1000 lbs.

FEATURES

RH control constancy of $\pm 0.5\%$

Temperature control constancy of $\pm 0.2^\circ\text{C}$

Various safety cut-offs

316 stainless interior chamber

User-friendly and unit-specific digital Controller

BENEFITS

Extremely stable and uniform environment

Maintains superior constancy and uniformity

Security and safety

Equipment longevity; corrosion resistant

Ease of operation

Chamber Range

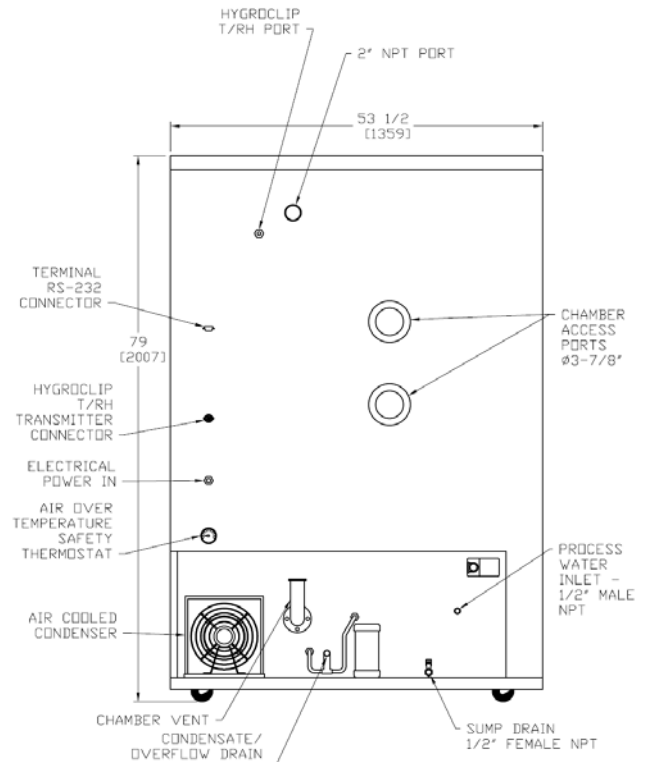
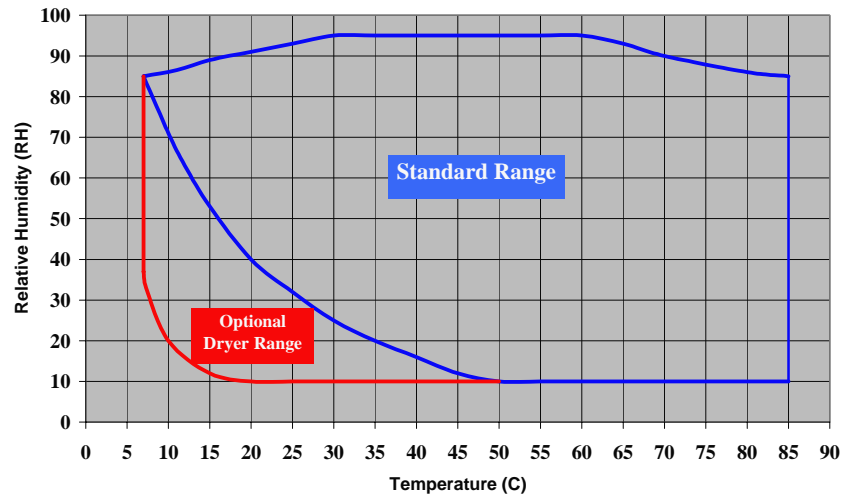

PARAMETER GENERATION & CONTROL

PO BOX 129, 1054 OLD US 70 WEST, BLACK MOUNTAIN, NC 28711

800.438.5494 www.humiditycontrol.com

sales@humiditycontrol.com